

BRIDGE RAILING ELEVATION

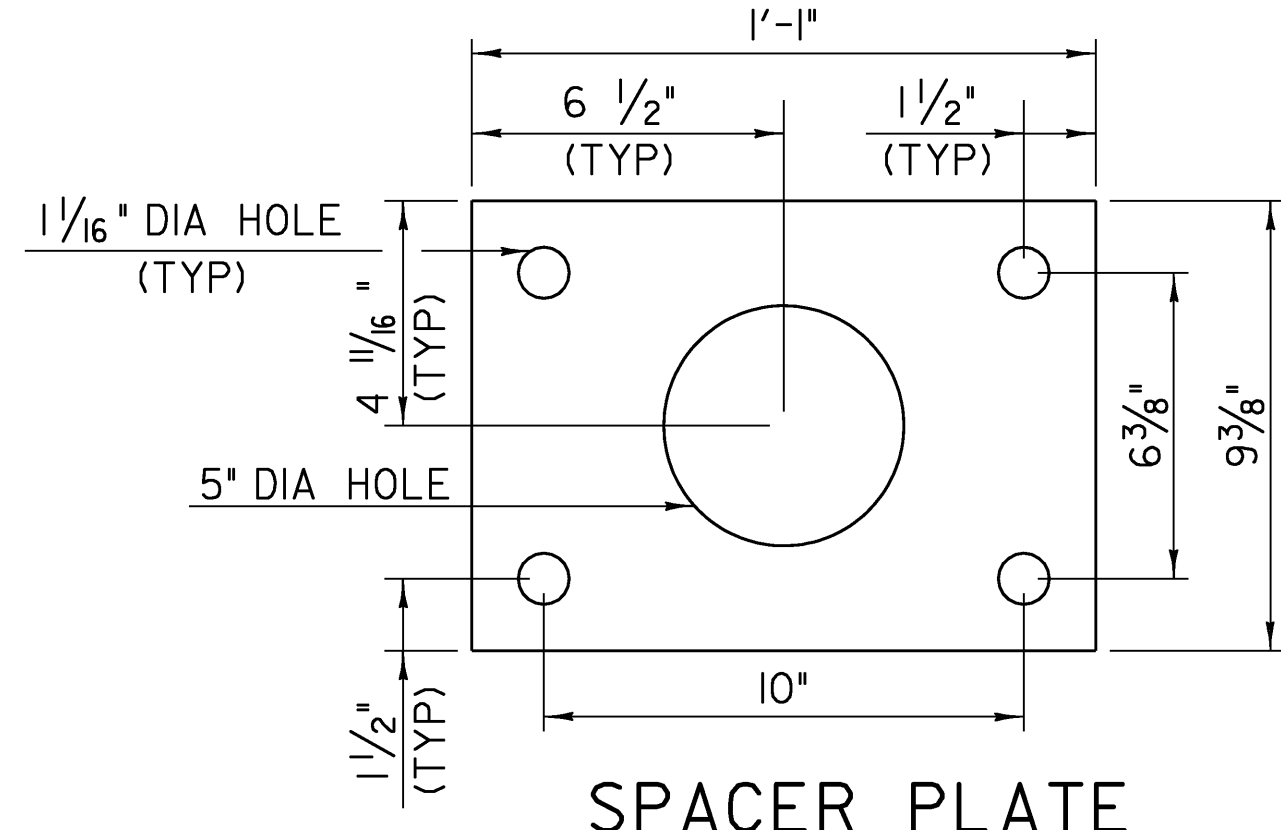

SPACER PLATE

NOTES

1. ALL WORK AND MATERIALS SHALL CONFORM TO THE PROVISIONS OF SECTION 525.
2. ALL EXPOSED CUT OR SHEARED EDGES SHALL BE ROUNDED TO A 1/16" RADIUS AND BE FREE OF BURRS.
3. RAIL POSTS SHALL BE SET NORMAL TO GRADE.
4. SECTIONS OF RAIL TUBE SHALL BE ATTACHED TO A MINIMUM OF TWO (2) RAIL POSTS AND PREFERABLY TO AT LEAST FOUR (4) POSTS.
5. RAIL TUBE EXPANSION JOINTS SHALL BE PROVIDED IN ANY RAIL BAY SPANNING A SUPERSTRUCTURE EXPANSION JOINT. EXPANSION JOINT WIDTH SHALL BE "X" AT 45°F AND WILL BE ADJUSTED IN THE FIELD BY THE ENGINEER FOR OTHER TEMPERATURES.
6. ALL PARTS SHALL BE GALVANIZED AFTER FABRICATION IN ACCORDANCE WITH AASHTO M111, EXCEPT THAT HARDWARE SHALL MEET THE REQUIREMENTS OF AASHTO M232.
7. RAIL POSTS ANCHORING NUTS SHALL BE TIGHTENED TO A SNUG FIT AND GIVEN AN ADDITIONAL ONE-EIGHTH TURN.
8. RAIL TUBES SHALL BE ATTACHED USING 3/4" FULL DIAMETER BODY AASHTO M164 (TYPE 1) ROUND HEAD BOLTS INSERTED THROUGH THE FACE OF THE TUBE. HOLES IN POSTS SHALL BE 1/16" LARGER THAN THE BOLT SIZE.
9. HOLES IN RAILS FOR RAIL TUBE ATTACHMENT MAY BE FIELD-DRILLED. HOLES SHALL BE COATED WITH AN APPROVED ZINC-RICH PAINT PRIOR TO ERECTION.
10. ANY BENDING OF RAIL SHALL BE BY SHOP PROCEDURE ONLY.
11. THE FABRICATOR SHALL SUBMIT DRAWINGS INCLUDING WELDING PROCEDURES TO THE STRUCTURES SECTION FOR APPROVAL IN ACCORDANCE WITH THE PROVISIONS OF SUBSECTION 525.03. ALL WELDING SHALL CONFORM WITH SUBSECTION 506.10.
12. RAIL POSTS AND BASE PLATES SHALL BE TESTED FOR IMPACT PROPERTIES IN ACCORDANCE WITH ASTM A-370 CHARPY IMPACT TESTING USING TYPE A SPECIMEN.

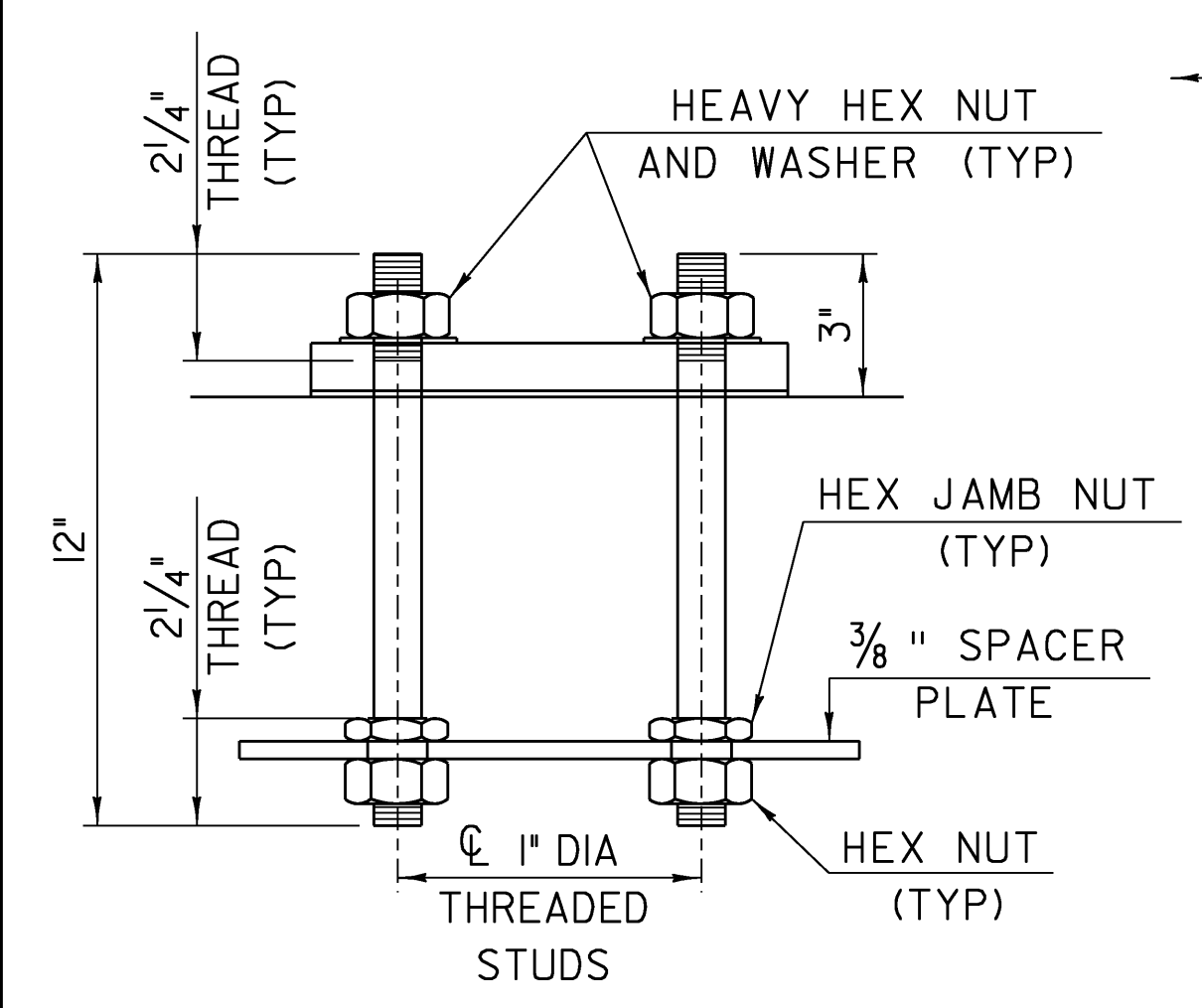

RAIL POST ANCHORAGE

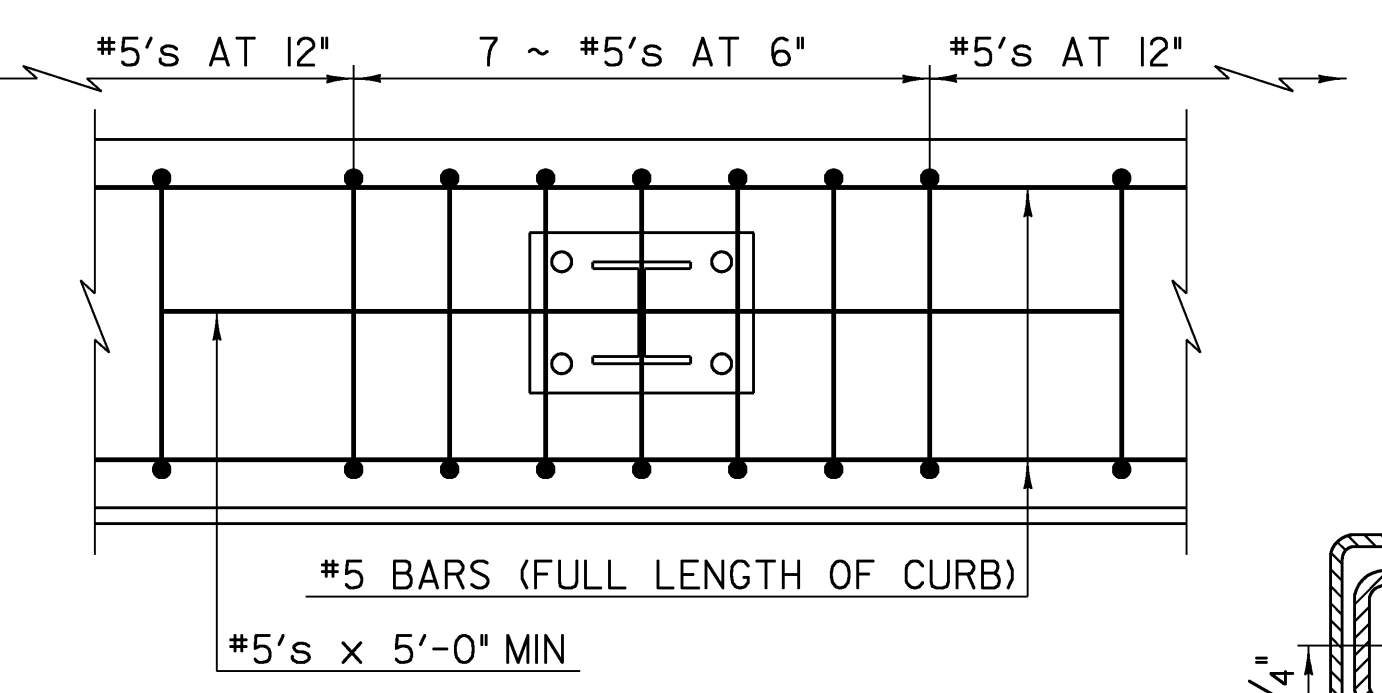

CURB REINFORCING PLAN

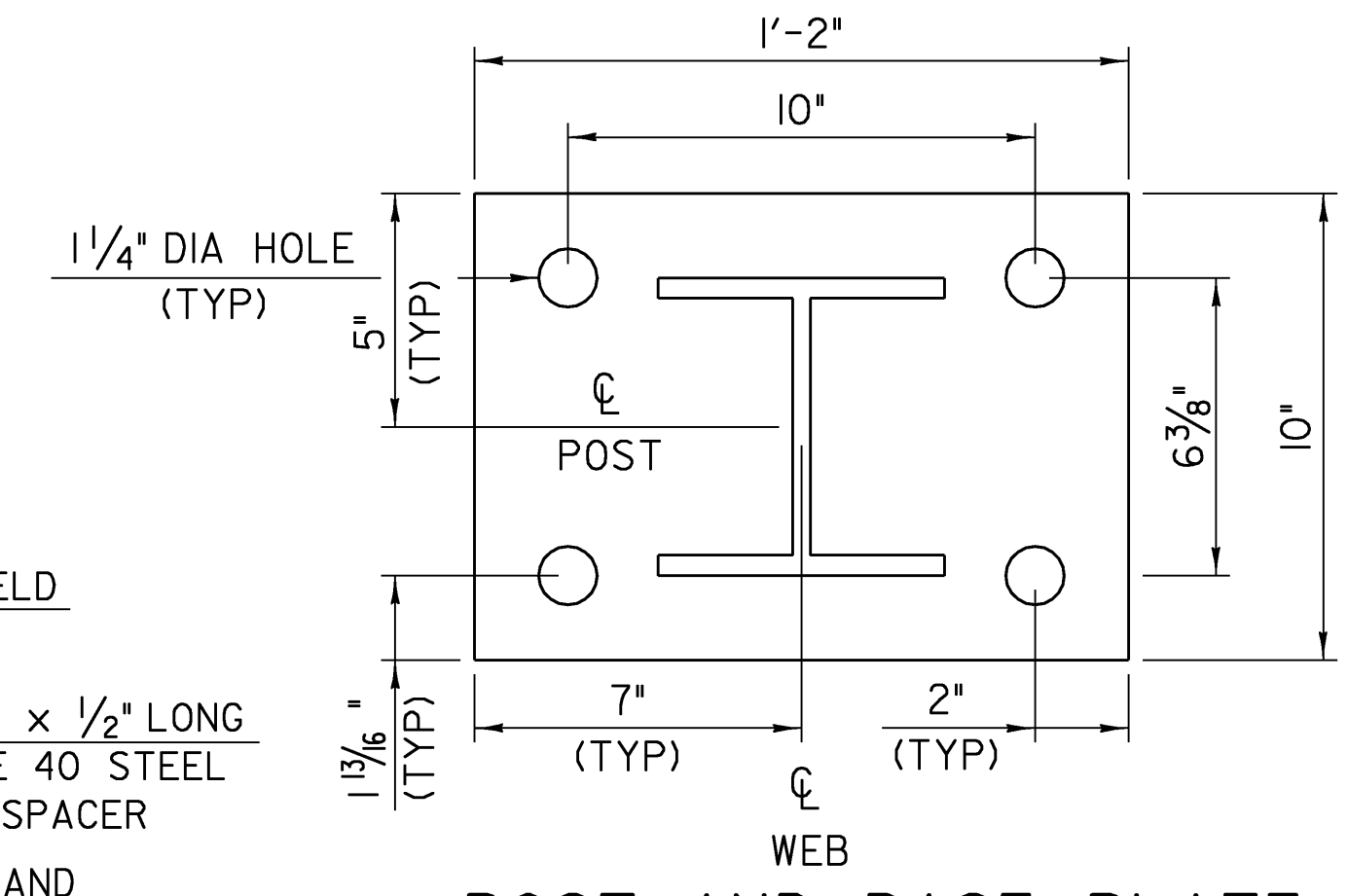

POST AND BASE PLATE

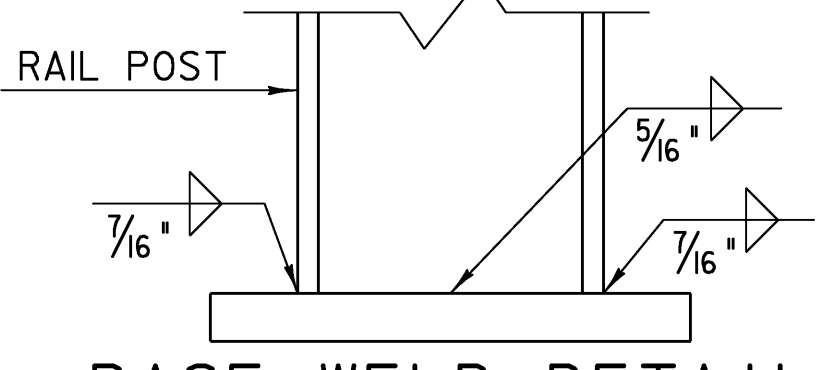

EXPANSION JOINT SECTION

FOR DETAILS NOT SHOWN, SEE "RAIL TUBE SPLICE SECTION."

SPLICE TABLE					
T	A	B	C	L	X
N/A	4"	2"	--	20"	3/4"
EXPANSION JOINT TABLE					
<4"	4"	2"	2 1/2"	20"	2 1/2"
>4" <6 1/2"	5 1/2"	2 3/8"	3 1/2"	23 3/4"	4"
>6 1/2" <9"	6 1/2"	3 3/8"	9"*	27 3/4"	5"
>9" <13"	8 1/2"	4 3/8"	11"*	33 3/4"	7"

T = TOTAL MOVEMENT BETWEEN BRIDGE EXPANSION JOINTS. SEE NOTE 6.  
\* = SINGLE SLOT

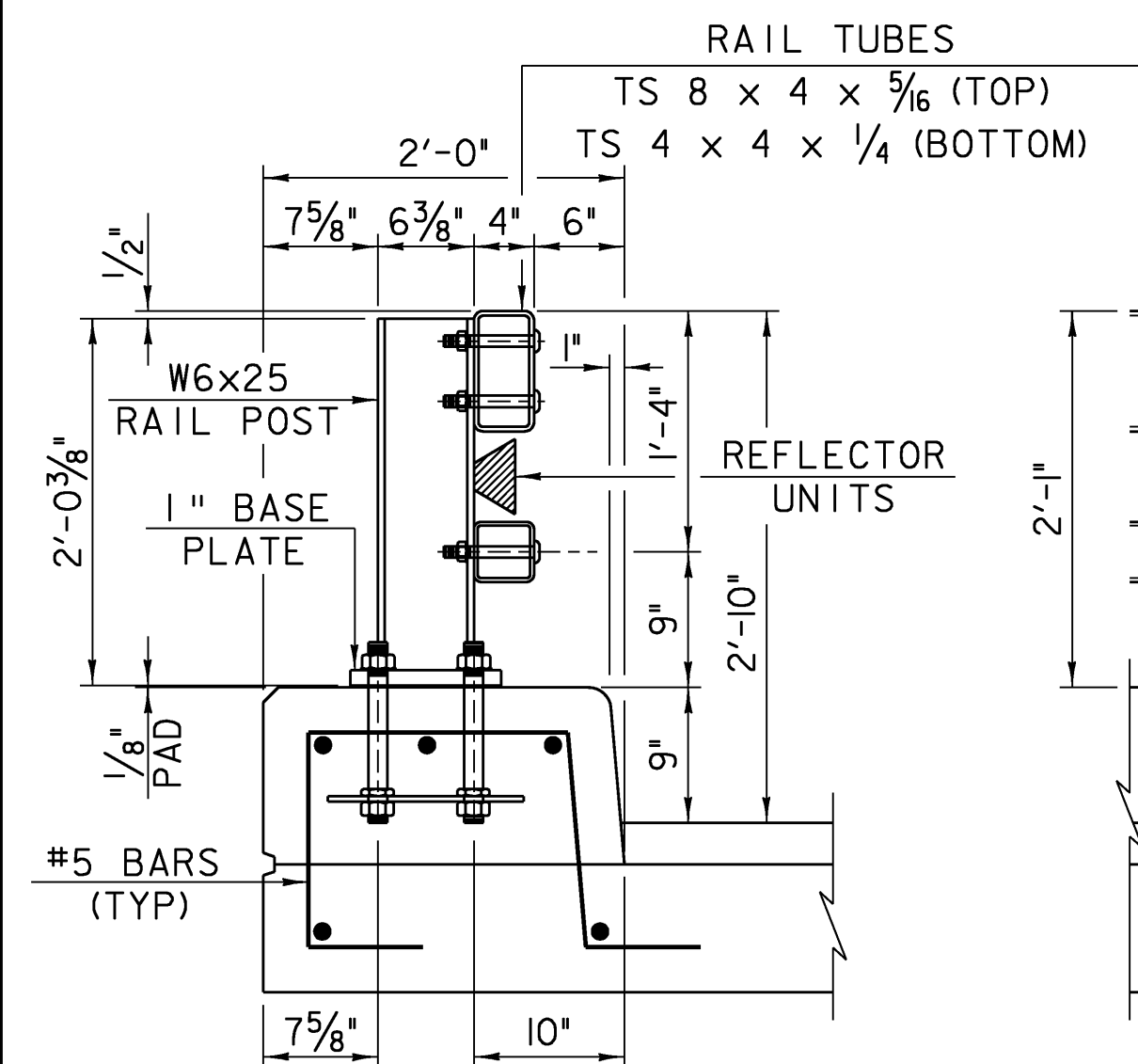

TYPICAL SECTION

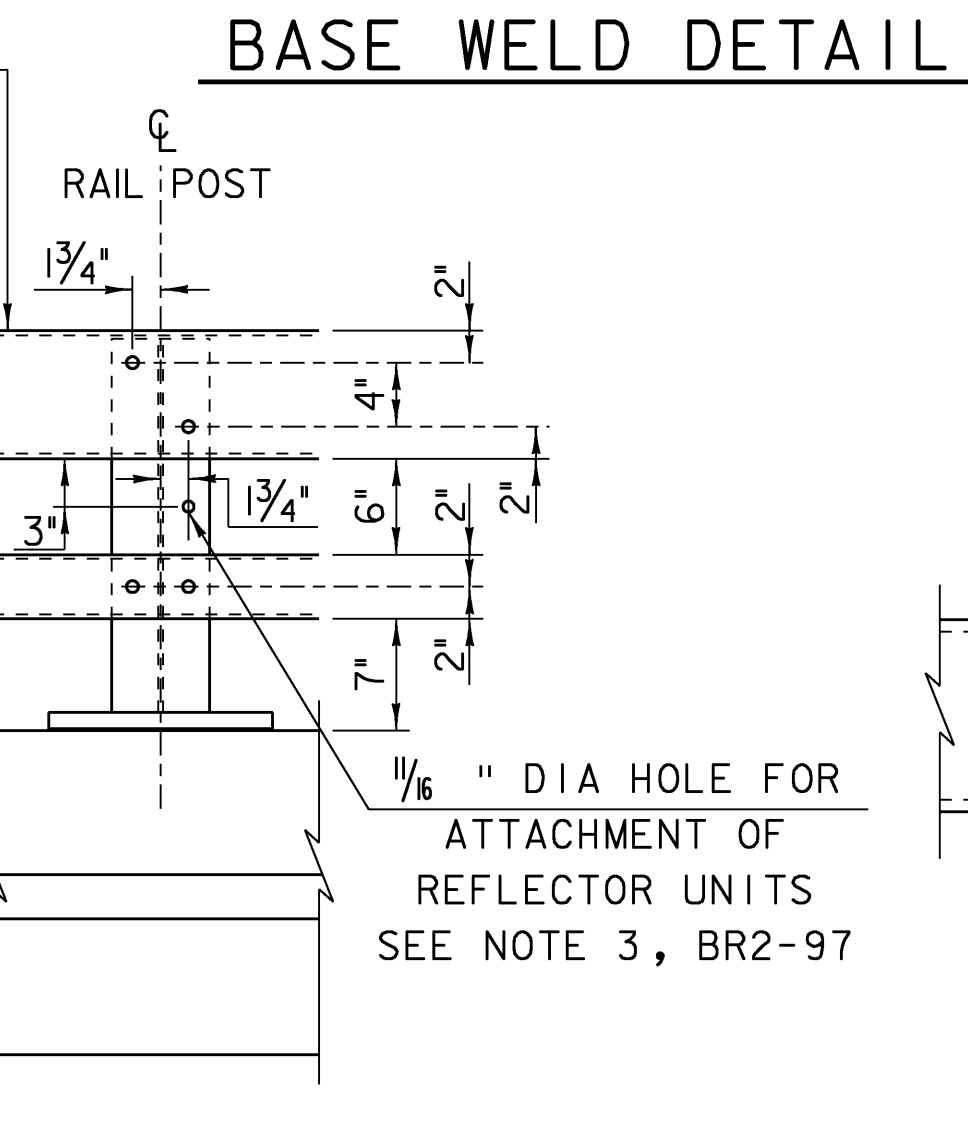

ELEVATION

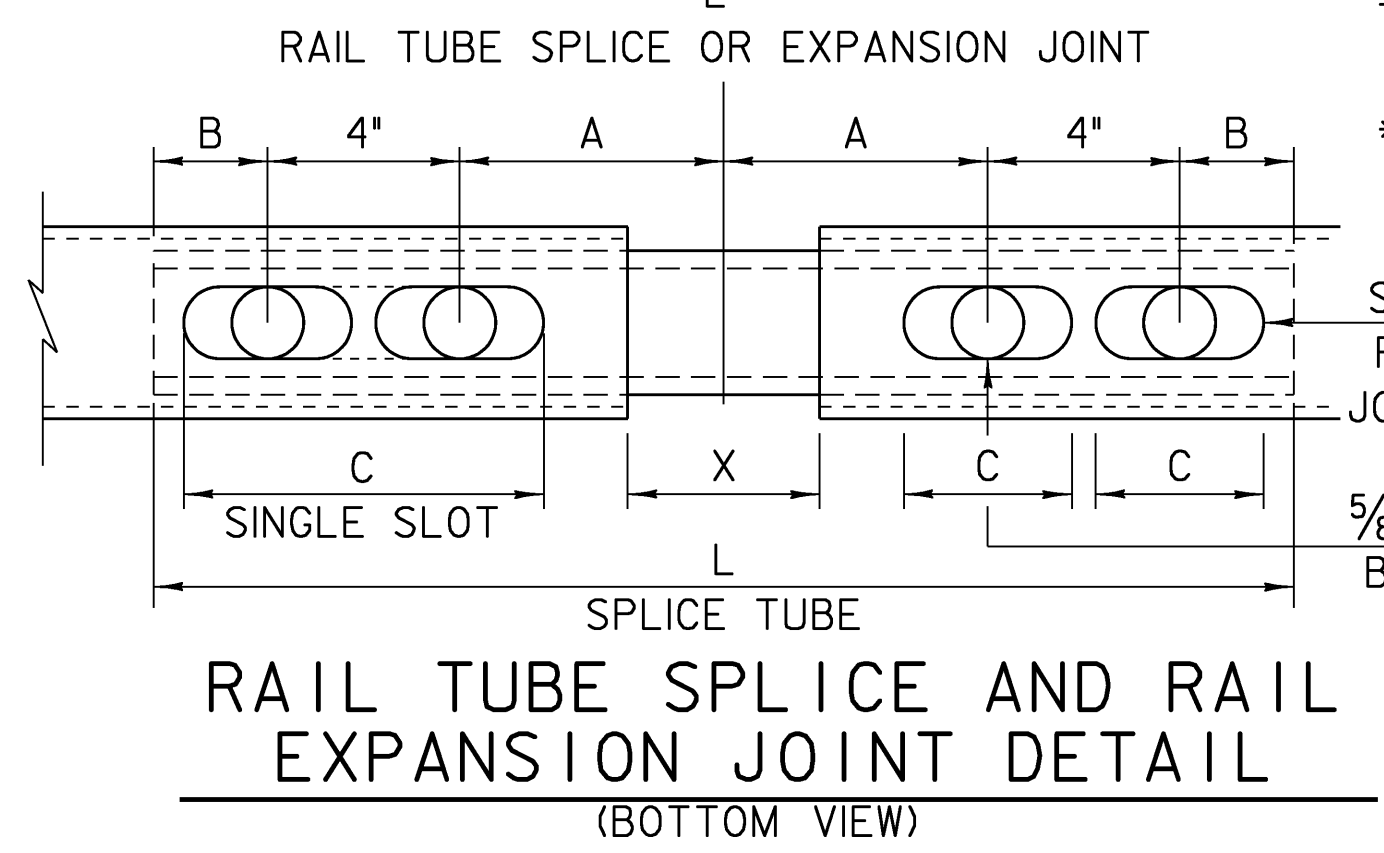

3/4" DIA M164 (TYPE 1) ROUND HEAD BOLT (WITH WASHER AND PREVAILING TORQUE TYPE LOCK NUT) ONLY FULL DIAMETER BODY BOLTS WILL BE ALLOWED.

MATERIALS

RAIL TUBES.....ASTM A500, GRADE B OR ASTM A501  
RAIL POSTS AND BASE PLATES.....ASTM A709A709M, GRADE 50  
ALL OTHER SHAPES AND PLATES.....ASTM A709/A709M, GRADE 36  
ANCHOR STUDS.....ASTM A449  
ALL OTHER BOLTS (UNLESS NOTED).....AASHTO M164, TYPE 1

NUTS FOR AASHTO M164 (ASTM A325) BOLTS AND FOR ANCHOR STUDS SHALL COMPLY WITH AASHTO M291 (ASTM A563).

WASHERS SHALL COMPLY WITH AASHTO M293 (ASTM F436) SPECIFICATIONS.

1/8" PAD SHALL COMPLY WITH STANDARD SPECIFICATION SUBSECTION 731.01 OR 731.02.

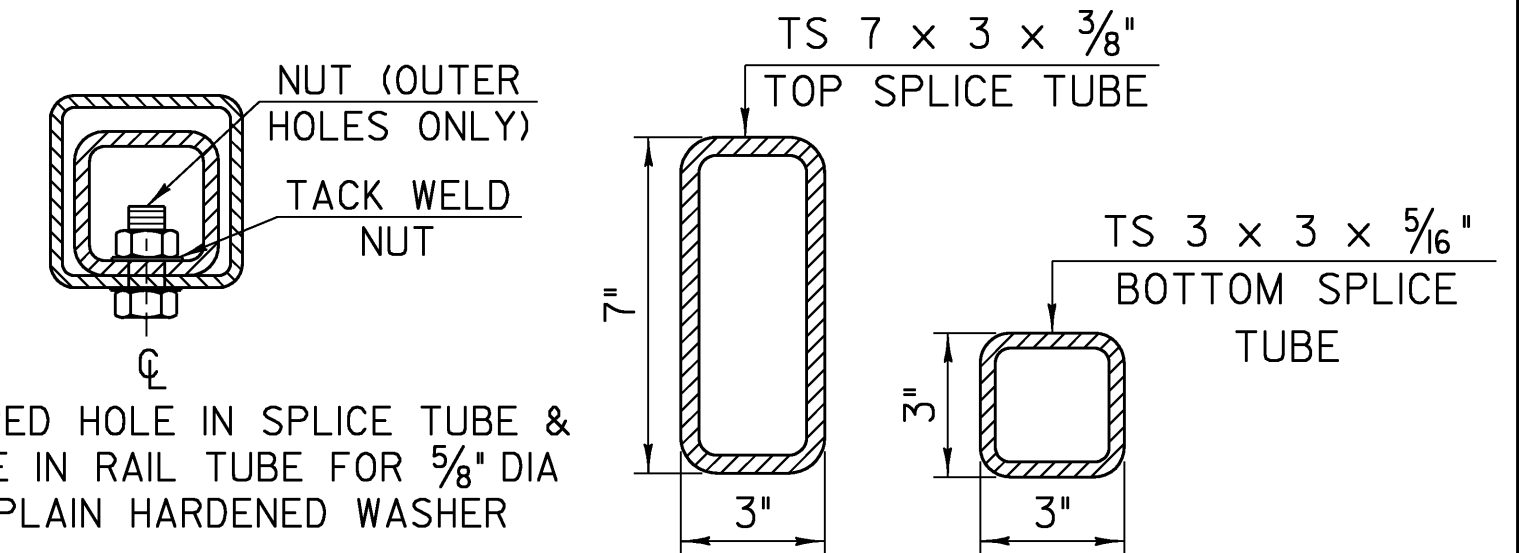

RAIL TUBE SPLICE SECTION

NETC RAIL DETAILS (2)

PROJECT NAME: CANAAN	PLOT DATE: 18-AUG-2008
PROJECT NUMBER: ER ST 0271(16)	DRAWN BY: L. DUQUETTE
FILE NAME: 04c098/struc./s04c098d.tls	CHECKED BY: S. SCRIBNER
DESIGNED BY: S.SCRIBNER	SHEET 49 OF 66